

# HZ160/160J

## SELF-PROPELLED ARTICULATED BOOMS

# Mantall®

### Standard Features

- Self-leveling platform
- Hydraulic rotation platform
- Hall effect fully proportional controls
- Driving confirm
- AC wiring to platform
- Horn
- Hour meter
- Tilt alarm
- Positive traction drive
- Dual Speed motor
- Emergency pump
- CAN intelligent control
- Overload Sensor

### Options Features

- Platform swing gate
- Platform alternate leverage
- Airline to platform
- Hydraulic oil cooler
- Hostile environment packages
- Anti-crash air packages
- Tool tray
- Alarm packages
- Platform work lights



# HZ160/160J

MODEL	HZ160	HZ160J
Max. Working height	16 m	16 m
Max. Platform height	14 m	14 m
Max. Outreach	8.22 m	8.32 m
Max. Up and over clearance	6.92 m	7.47 m
Max. Lift capacity	230 kg	
Platform size <b>B</b> x <b>C</b> x <b>A</b>	1.5 x 0.76 x 1.1 m	
Height - stowed <b>D</b>	2.00 m	
Length - stowed <b>E</b>	5.88 m	6.47 m
Width <b>F</b>	1.75 m	
Wheelbase <b>G</b>	2.00 m	
Ground clearance <b>H</b>	0.14 m	
Turntable rotation	360° discontinuously	
Turntable tailswing	0	
Platform rotation	180°	
Jib Swing	0/140°(HZ160J only)	
Platform Level	Hydraulic level	
Drive speed - stowed	4.8 km/h	
Drive speed - raised	1.0 km/h	
Gradeability	30%	
Max. tilt angle	3°	
Max. lateral force N	400 N	
Max. Wind speed allowed	12.5 m/s	
Min. Turning radius-(inside)	1.1 m	
Min. Turning radius-(outside)	3.50 m	
Drive wheels number	2	
Steering wheel number	2	
Controls	Electrical hydraulic proportional control	
System voltage	DC 24V	
Hydraulic tank capacity	35 L	
Tire size	600 x 190 mm	
Power	DC 48V / 320 Ah	
Total weight	6.49 t	6.64 t

Range of motion HZ160

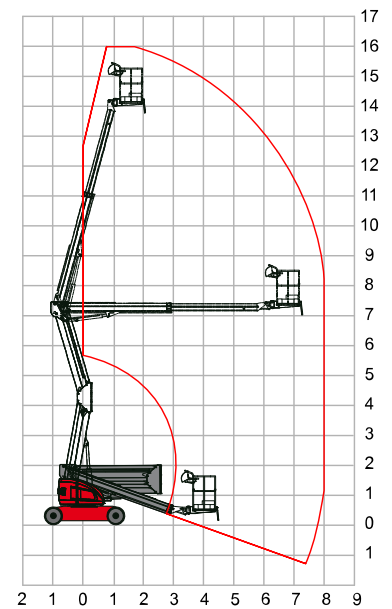

Range of motion HZ160J

